



R. "LYNN" RUFFELL

316 West Milwaukee Street; P.O. Box 511

New Hampton, IA 50659

P: 800-222-6047 x230 IC: 208-569-4061

lynn@zips.com |www.zips.com



TRAILMAX[®]
Quality Trailers From
Gem State Manufacturing, Inc.

"For The Long Haul"

GTD-24-HT

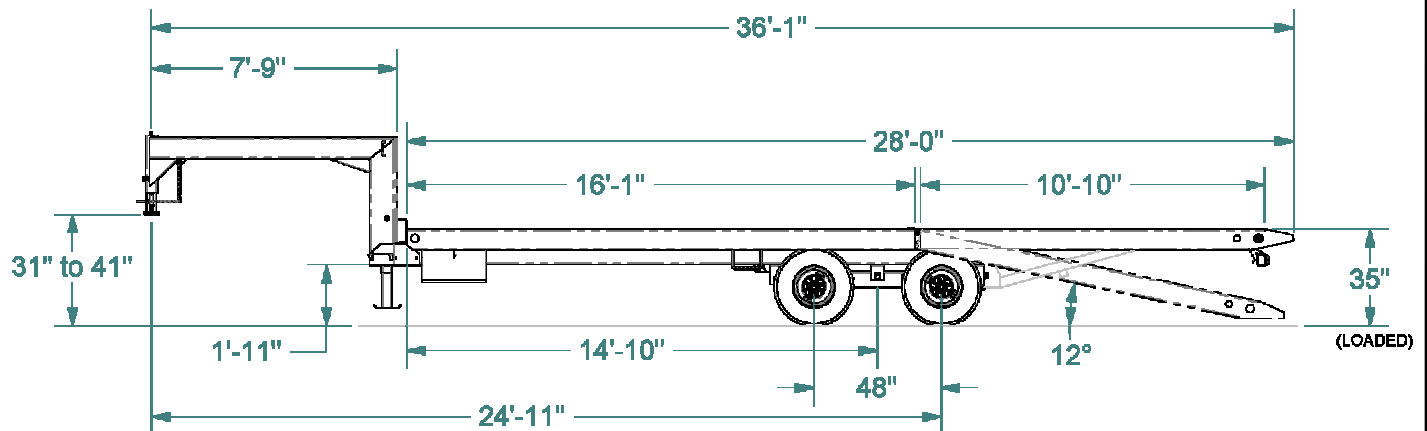

| | |
|------------------------|---|
| Capacity (Distributed) | 18,200 lbs |
| G.V.W.R. | 26,000 lbs |
| Base Trailer Weight | 7,800 lbs |
| Frame Construction | 8" Tubular |
| Crossmembers | 4" Tubular on 16" centers |
| Hitch | 2-5/16" Ball, 30,000 lb. capacity, adjustable |
| Deck Width | 102" |
| Jack | 12,000 lb. capacity with drop foot |
| Load Securement | 16 ea. 2-way Chain Slot/Stake Pocket |
| Hydraulic System | 12 volt DC electric system / Hydraulic self contained |
| Axles | 2 ea. 12,000 lb capacity |
| Hubs | Oil bath type, 8 on 6.5 BC |
| Brakes | 12-1/4 x 3-1/2 electric |
| Suspension | 3-point with axle adjustment capability |
| Wheels | 16" x 6" 8 hole disc type. 8 on 6.5 BC |
| Tires | 235/80R16 Load Range E |
| Finish | 5 stage pretreatment with two component epoxy primer and two component urethane enamel top coat, standard color white |
| Electrical | Trucklite modular system with rubber isolated, sealed beam |
| Decking | 2" rough surface No. 1 Grade fir with fasteners at all crossmembers |
| Various Options | Spare Tire, Apitong Deck, Traction Devices, D-Rings, Belt Winches, Outriggers, Custom Paint and Decal |

Specifications are subject to change without notice

"Setting the Industry Standard"

Maximum performance
Maximum reliability
Maximum return on investment